

Morgana FB1180<sup>T</sup> | FB780<sup>T</sup> | FB580  
B1, B2 & B3 Digital-Die Flatbed Cutter/Creaser

# ColorCut flatbed cutting tables

Our **flatbed cutting table** range is **designed in the UK, beautifully engineered, totally accurate and highly affordable** - defining a new industry standard.



Perfect for light to medium production of two and three dimensional items, the ColorCut series offers a range of machines to suit the cutting and creasing of virtually any form of print from cardboard packaging and protective cartons to synthetic point of sale and kiss cut stickers/labels. And with the ability to digitally produce items on demand, also makes ColorCut perfect for prototyping.

Combined with our industry leading ColorCut Pro software, all models in the range bring advanced features to aid design and production.

## One solution with model choices

ColorCut flatbeds come complete with a selection of creasing tools, industrial cutting blades and superior cutting mats to suit a wide range of materials being cut including N/F/E fluted boards, mount boards, FBB, lightweight cards, papers, sticker/label stock and synthetic substrates.

Choose your model to create stunning packaging with superb creasing and crisp cut lines/perforations on heavier-weight stocks. Also nothing new to learn. The simple and intuitive ColorCut Pro software, that is supplied with the cutters, enables you to work directly with the leading graphic design applications; Adobe® Illustrator® or CorelDRAW® enabling you to use the design software you already know.



## Designed and developed to deliver the accuracy, speed, ease-of-use and reliability demanded by print professionals.

- **Engineered for reliability.** Designed in the UK, the ColorCut flatbed range has a pedigree of solid engineering, robust mechanical parts and the latest high-tech electronics for ease of use - all at an extremely affordable price point!
- **Digital die cutting** - advanced digital contour cutting – no need for traditional die.
- **Deliver on demand** - cuts a typical SRA3 sheet in just 30 - 60 seconds - produce singles or as many as 1,000 sheets per day.
- **Vacuum hold down table** - sheets are held securely in place by a vacuum produced from a powerful centrifugal air pump.
- **Job sensing** - accurate crease and cut registration to the printed sheets with SmartMark and QR code reading.
- **Batch productivity** - Multiple sheet cutting helps to speed up productivity.
- **Cutting heads** - delivering over twice the pressure of other models in its class, the ColorCut flatbeds use a tool head where tools operate independently from each other, for all functions.
- **Fingertip control** - the intuitive touch screen control panel integrates with included ColorCut Pro (see software section).
- **High power vacuum included** - all Morgana ColorCut flatbeds come with an extremely powerful centrifugal air pump which provides the power, to hold down printed sheets. An auto cut-off feature announces the end of each cut job. The pump is housed within an attractive, purpose made acoustic housing and supplied with an effective silencer\*.

\*optional for the FB580 model

# ColorCut flatbed cutting tables

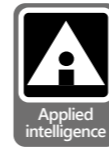

Quad or Dual tool head for rapid cut and crease capability



Standalone - NO WIRE job processing from a USB drive



QR job coding delivers multiple and mixed job functionality

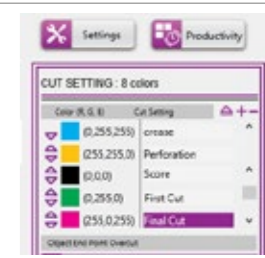

Powerful, yet easy to use ColorCut Pro software included

## Tangential and contour tool control

The Morgana ColorCut flatbeds offer a choice of tools to include Passive Contour and Active Tangential cutting and creasing. This provides different finishing options for varying media types and is model dependent (see model selector page).

**Tangential tools** are active tools where the direction of the tool is controlled by a motor. Tangential technology enables tools to be lifted up from the media, rotated and lowered back into the media. Suitable for creasing wheels for a smooth more defined crease or to enable deeper, precise cuts for thicker (often fluted) stock. In contrast, a passive **contour tool** remains in the media during cutting or creasing, dragging the tool which will passively rotate faster, but suited to thinner card and labels.

## Enhanced control

The cutters are built on the foundation of Morgana's next generation of Ai based ColorCut software which delivers new features, functionality and control redefining how flatbed cutters can be used, easily, simply and autonomously by providing 2 modes users can employ for cutting files.

**DIRECT mode:** ColorCut Pro offers unparalleled flexibility and control over cutting and production enabling all options to be adjusted on the fly.

**HELD mode:** ColorCut Pro stores your job parameters, wrapping all the required settings into a custom held mode cut file, that can be transferred via a storage device to the cutters. This enables standalone operation, without the need for the main PC.

Held mode is ideal for **repeat cut jobs** that need to be **cut at any time, by any user.**



## ColorCut Pro 5

ColorCut Pro has been developed exclusively by Morgana to work the way you work! No new software to learn when designing your jobs, offering key productivity features to deliver exactly the kind of user experience that we know the print finishing industry demands.

## QR Code Reading

The flatbeds utilise 9th generation ARMS technology, with an on board Vision3 CCD video camera, scanning the QR code, to instantly retrieve the associated cut/crease file and read SmartMarks for perfect registration.

This system works with the FB580, FB780-T and FB1180-T models and other Morgana auto feed ColorCut finishing solutions. Enabling you to add more Morgana cutters to your line up, moving jobs between devices easily.



QR code & SmartMark for CCD camera recognition

**100% digital - no physical dies**

# ColorCut FB580

Compact dual tool cutting table with crease ball tool for **creasing heavy stock**, and a contour blade tool for **exceptional cutting**.



The FB580 flatbed is a dual tool cutter/creaser providing exceptional creasing and precision cutting, for die-cut and kiss-cut applications.

A compact designed cutting table that includes 2 tools, both with an impressive 1.2kg force for its Passive Contour/Drag Cutting tool and Passive Creasing Ball tools. Combined with a powerful vacuum system and high speed performance, it is ideal for on demand, small to medium production runs.

This powerful and accurate device can cut and crease any shaped print, from sample and prototype packaging for high-end products and protective cartons to synthetic point-of-sale items and kiss-cut adhesive labels/stickers.

With our combined industry leading ColorCut Pro software, the FB580 is a **highly specified, yet incredibly affordable** entry level digital flatbed.

## Market leading features

- Dual tool head
- Highly productive
- QR driven jobs
- Standalone production
- Reverse Side
- Vacuum hold down

## B3 digital flatbed cutter/creaser

A compact B3 format flatbed cutting table with a dual tool head, which has **two independent tools** including a passive contour/drag cut tool and interchangeable ball crease tool (wide and narrow). The dual tool head enables users to complete two actions in 1 operation; for example CUT and CREASE.

With its **small footprint** yet **powerful feature** set this model is ideal for small commercial printers, graphic design, media and marketing companies or in-plants.



Cut and crease in one operation

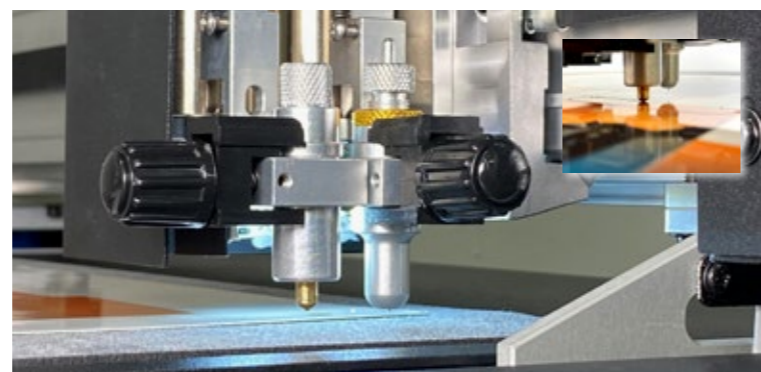

Dual tool head for rapid cut and crease

# ColorCut FB580



<b>TOOL head</b> Process thicker media	<b>HI-FORCE 1.2kg</b> Clean cuts, crisp creases	<b>HI-SPEED 1200 mm/Sec</b> Productive fast output
<b>QR</b> QR code driven jobs	<b>Media edge detection</b> Reverse side cut & crease	<b>7 inch TOUCH SCREEN</b> Immersive operation
<b>NO WIRES</b> Cut without cables	<b>USB drive</b> Direct Drive - cut from USB	

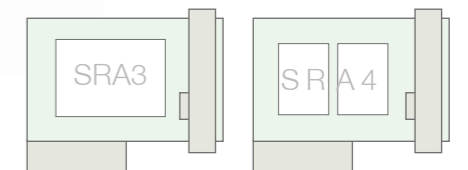

## Primary features

**Dual tool head** - independently operated tools include; Passive contour/drag knife cutting and crease ball tools for a truly versatile media capability.

**Highly productive** - high speed and high pressure cut and crease, for production and prototyping of single sheets.

**QR driven jobs** - instantly & automatically finds cut files.

**Standalone production** - the 'NO WIRES' file system. Load jobs from a USB drive, view and display jobs on the large touch screen, select them by name, or press the SCAN button and the cutter will auto-select the correct cut file and cut the job on the cutting table. One million job capacity.

**Reverse side scanning** - patented technology enables you to scan marks on the front of your sheet, flip the sheet over and cut and crease from the rear - offering more cutting and creasing options depending on media selection.

**Vacuum hold down** - includes a powerful 400W vacuum\* system that keeps cut pieces firmly in place, for fast and accurate processing, yet provides a quiet & comfortable operating environment. \*Optional acoustic muffler

## Creasing Tools

Passive ball creasing tools for laminated and unlaminated stocks - wide and narrow options.

## Cutting blades and tools

Passive contour/drag knife cutting tool. Drag blade set - included with standard and circlip blades in 30°/45° and 60° angles.

## Media compatibility

- Folding box board, SBS, SBB and sheet card
- Paper
- Rice and icing paper
- Synthetics and polymers,
- Sheet labels and vinyl's

Tangential SERIES ColorCut FB780-T

Dual head cutting table with active **tangential wheel** for **creasing heavy weight stock**, and with passive contour blade tool for **exceptional cutting**.

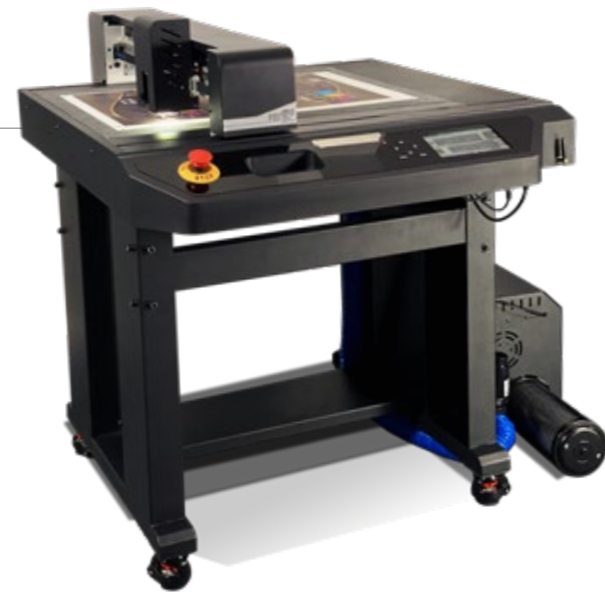

The NEW FB780-T is the world's first B2 flatbed cutter with the ultimate crease and precision cutting for any shaped die-cut application.

This compact designed cutting table includes 2 tools; an impressive **2.5kg Active Tangential Creasing Wheel** and Passive Contour Cutting tool, combined with a powerful vacuum system and high speed performance, ideal for on demand, small to medium production runs.

This powerful and accurate device can cut and crease virtually any form of print, from sample and prototype packaging for high-end products and protective cartons to synthetic point-of-sale items and kiss-cut adhesive labels/stickers.

With our combined industry leading ColorCut Pro 5 software, the FB780-T provides an intuitive solution for design production.

**Market leading features**

- Dual tool head
- Highly productive
- QR driven jobs
- Standalone production
- Reverse Side
- Vacuum hold down

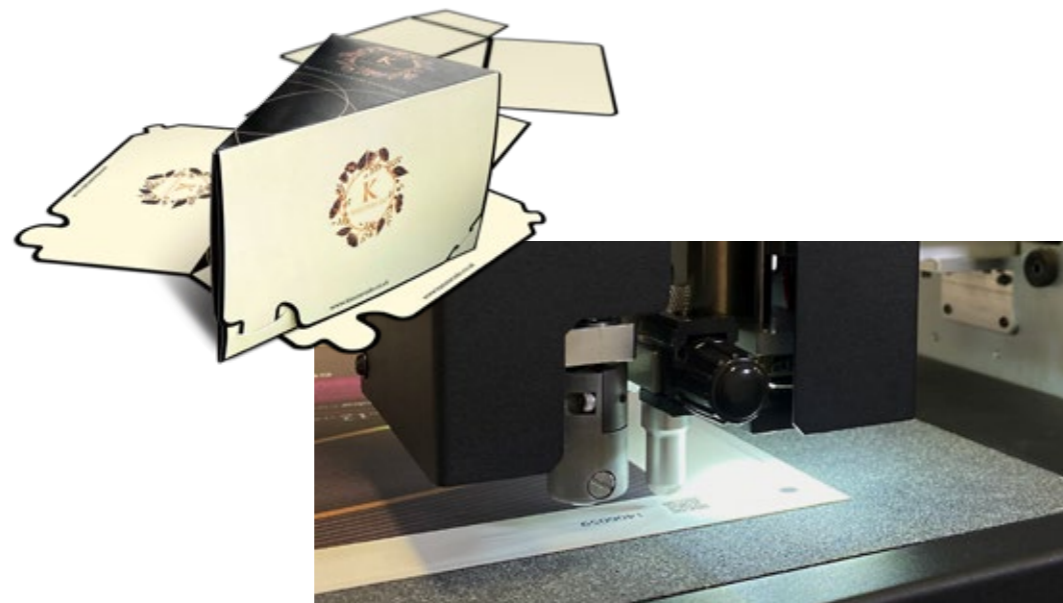

Dual tool head for rapid cut and crease includes tangential crease capability

**B2 Tangential digital flatbed cutter/creaser**

This B2 medium format flatbed cutting table has two independent tools in the carriage head including an active **tangential crease wheel tool** and **passive contour**/drag cut tool for cutting blade.

The combination of an Active tool and Passive tool provides a much wider media handling capability and more defined, **smooth crease** for thick card up to 800 microns.

Individual tool actions can be set to apply exact amounts of pressure and speed, along with total control over the application of cut, crease, perforation or kiss-cut.

The larger bed size lends itself to higher productivity where 2 up SRA3 or 4 SRA4 sheets can be placed next to each other for light production, making this a very popular model.

Tangential SERIES

ColorCut FB780-T

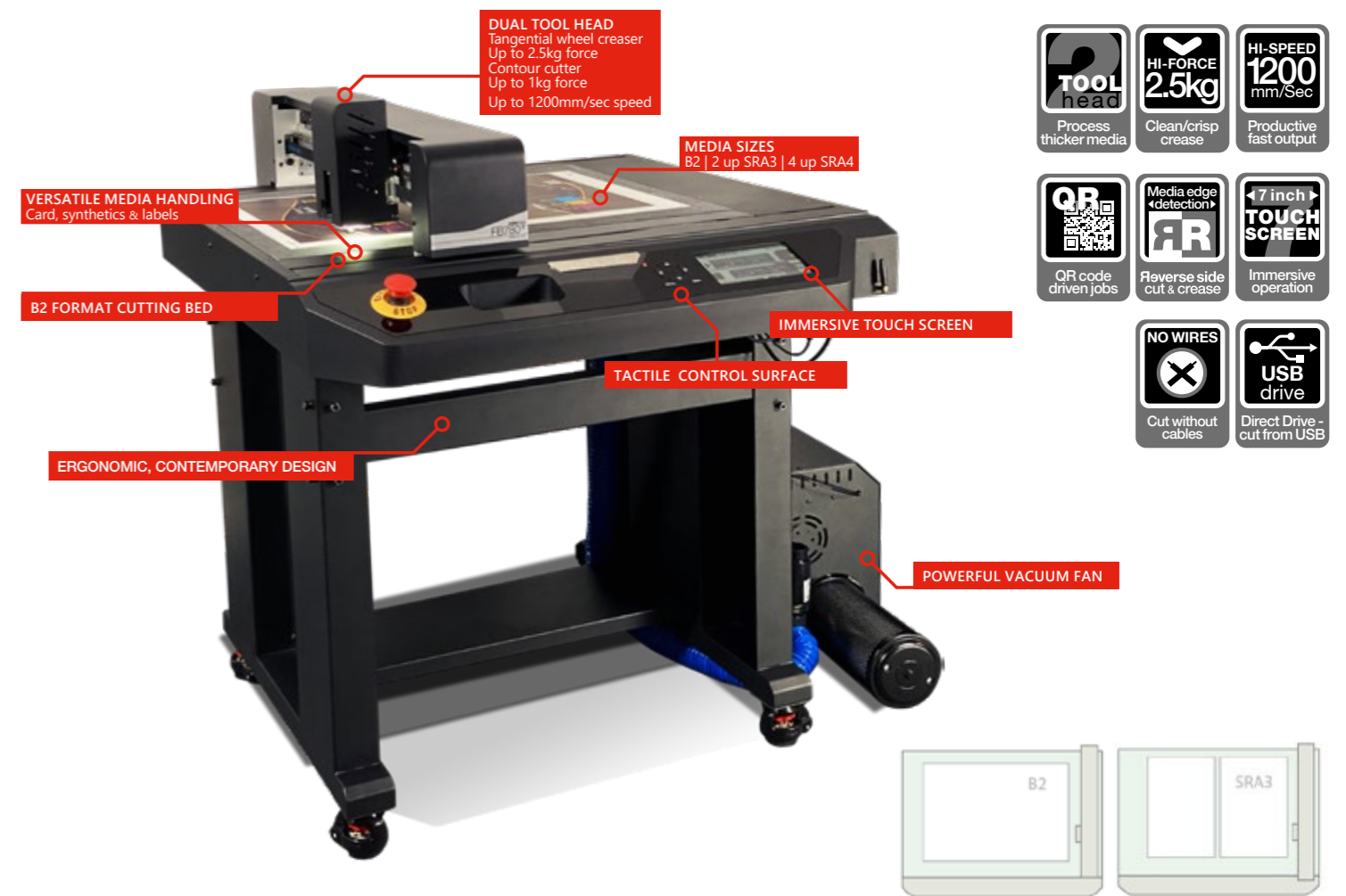

**Primary features**

**Dual tool head** - includes Passive drag and Active crease tangential tools for a truly versatile media capability.

**Highly productive** - high speed and high pressure cut and crease, for prototyping of singles or multi-sheet 2/4 up rapid production for more jobs.

**QR driven jobs** - instantly & automatically finds cut files.

**Standalone production** - the 'NO WIRES' file system. Load jobs from a USB drive, view and display jobs on the large touch screen, select them by name, or simply auto-select the correct cut file and cut the job by pressing the SCAN button. One million job capacity.

**Reverse side scanning** - patented technology enables you to scan marks on the front of your sheet, flip the sheet over and cut and crease from the rear - offering more cutting and creasing options depending on media selection.

**Vacuum hold down** - includes a powerful 750W vacuum system with acoustic muffler that keeps cut pieces firmly in place, for fast and accurate processing, yet provides a quiet & comfortable operating environment.

**Creasing Tools**

Active Tangential creasing wheel. Incorporates magnetic positioning assist, for easy change-over of crease tool.

**Cutting blades and tools**

Passive contour/drag knife cutting tool. Drag blade set - included with standard and circlip blades in 30°/45° and 60° angles.

\*Optional active tangential blade for materials between 500-800 micron.

**Media compatibility**

- Folding box board, SBS, SBB and sheet card
- Paper
- Rice and icing paper
- Synthetics and polymers
- Sheet labels and vinyl's
- Magnetic media



# ColorCut FB1180-T

**B1 flatbed cutting table with quad tool head, includes 2 active tangential tools for crease and cut and passive contour/drag cut and crease.**

Super fast B1 flatbed cutter including 4 tools, both contour cutting tools and active tangential tools. The FB1180-T is precise enough to cut labels yet its amazing 4 tool selection provides users with the option to switch to high force cut and crease for thick N/F/E fluted media, and a diverse range of media in-between.

Perfect for on demand prototype pieces to light production runs of two and three dimensional items, the FB1180-T flatbed cutting table can cut and crease virtually any form of print, from sample packaging, to high-end products, protective cartons or synthetic point-of-sale items and kiss-cut adhesive labels.

### Market leading features

- Tangential & contour quad tool head
- Highly productive
- QR driven jobs
- Standalone production
- Reverse Side Scanning
- Vacuum hold down

### Media

- Folding Box Boards, SBS, SBB and sheet card
- Corrugated and mount boards
- N/F/E fluted boards
- Synthetics
- Paper/rice paper
- Sheet labels
- Magnetic media and more!



### B1 Tangential digital flatbed cutter/creaser

The FB1180-T offers the largest cutting table in the ColorCut range with an enhanced cutting head.

It's **quad tool head** includes **passive** contour/drag cut & crease tools PLUS 2 further **active tangential** tools, with full functionality for use with **creasing wheels** and **deep cutting** blades. This offers more flexibility to cut materials up to 3mm thick, yet its control and precision also allows for more delicate label sheets to be kiss-cut.

Users can maximise efficiency with its batch mode functionality by putting multi sheets up on the bed, making it is the most flexible and productive cutter in the range.

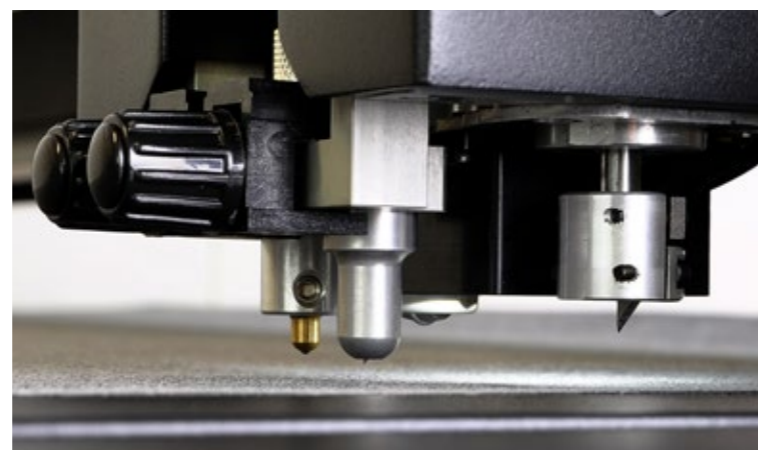

High force, rapid 4 tool head, includes 2 active tangential tools



# ColorCut FB1180-T

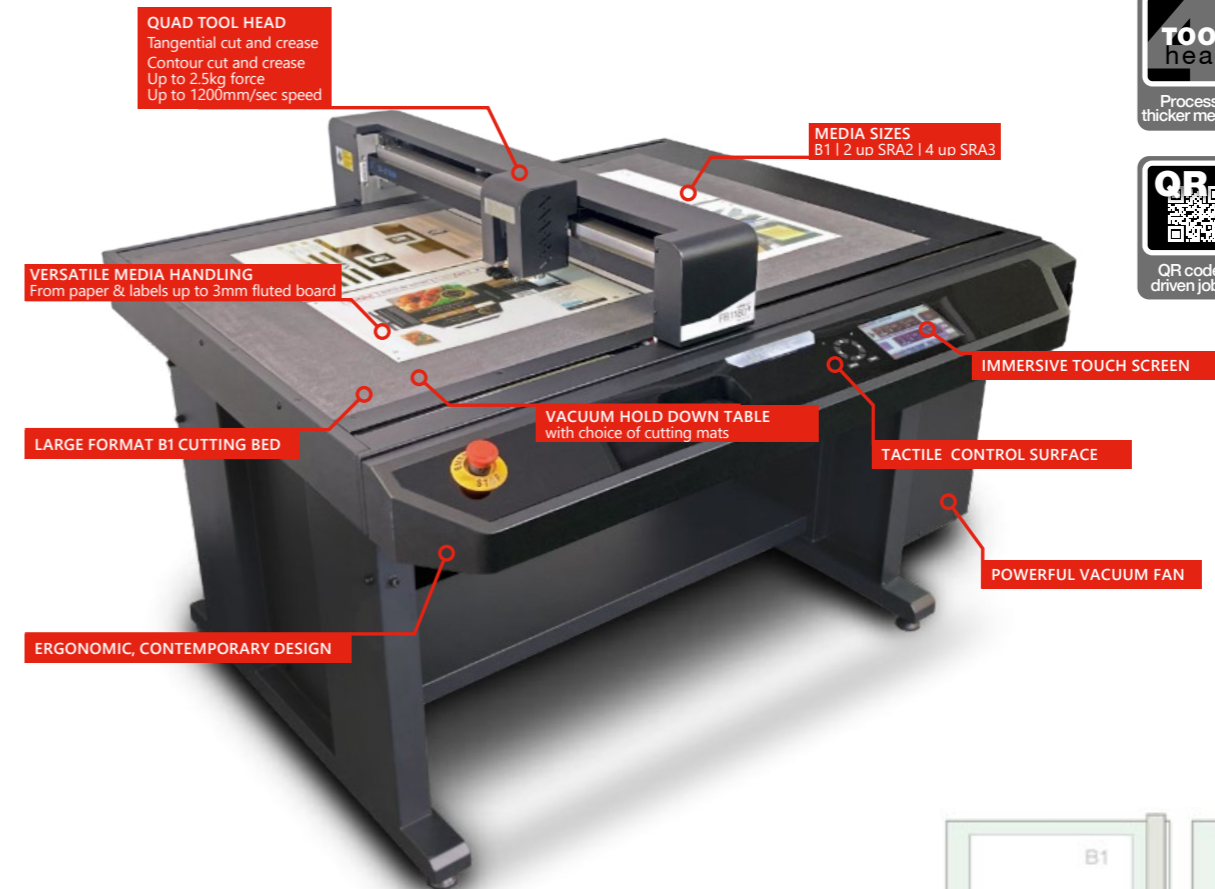

- TOOL head**  
Process thicker media
- HI-FORCE 2.5kg**  
Clean/crisp cut & crease
- HI-SPEED 1200 mm/Sec**  
Productive fast output
- QR**  
QR code driven jobs
- Media edge detection**  
Reverse side cut & crease
- 7 inch TOUCH SCREEN**  
Immersive operation
- NO WIRES**  
Cut without cables
- USB drive**  
Direct Drive - cut from USB



### Primary features

**Highly productive** - high speed and high pressure cut and crease, for prototyping of singles or multi-sheet 2/4/8 up rapid production for more jobs.

**QR driven jobs** - instantly & automatically finds cut files.

**Standalone production** - the 'NO WIRES' file system. Load jobs from a USB drive, view and display jobs on the large touch screen, select them by name, or simply auto-select the correct cut file and cut the job by pressing the SCAN button. One million job capacity.

**Reverse side scanning** - patented technology enables you to scan marks on the front of your sheet, flip the sheet over and cut and crease from the rear - offering more cutting and creasing options depending on media selection.

**Vacuum hold down** - Includes a powerful 1100W vacuum system with acoustic muffler that keeps cut pieces firmly in place, for fast and accurate processing, yet provides a quiet & comfortable operating environment.

**Quad tool head** includes passive contour/drag cut & crease, with active tangential tool functionality using alternate tool positions; suitable for use with creasing wheels and extended depth cutting blades.

### Creasing Tools

- Active Tangential Creasing Wheel with 2 interchangeable wheels included for different media types
- Passive Ball Creasing tools; one wide or one narrow for different media or crease width

### Cutting blades and tools

- Active Tangential cutting tool with deep knife 5mm / 45° blades x 3 Tangential blades included
- Passive contour/drag knife cutting tool  
Drag blade set - included with standard and circlip blades in 30°, 45° and 60° angles

# ColorCut Flatbed Model Selection

Depending upon typical **job type, run volumes** and **physical space**, there's a **ColorCut flatbed to suit** virtually all users!



# ColorCut Flatbed Model Selection



**FB580**

**Market position** Ideal for small commercial printers, graphic design, media and marketing companies or in-plants seeking to cut and crease on SRA3 or up to 350mm x 488mm sheets for on demand applications.

Produce one off's or hundreds of boxes for prototypes, packaging, greetings cards - up to 600 microns - also suitable for kiss-cut stickers and self adhesive label sheets.

Supplied with two creasing tools; narrow and wide for laminated and unlaminated sheets and an adjustable cutting tool, which accepts a range of blades, for different media types.

Add the optional silencer for a whisper quiet working environment.

**MODEL FEATURES FB580**

Maximum media area	350mm x 520mm
Effective contour cutting area	330mm x 488mm
Selectable Tools / Force	Tool 1: Passive Contour / Drag Knife Tool / 1,200gf Tool 2: Passive Contour / Drag Ball Crease Tool / 1,200gf
Cutting system	Blade Holder with Contour / Drag Knife Cutting Blade
Creasing system	Creasing Ball Tool (interchangeable narrow or wide)
Speed settings	High Definition / Standard / Fast
Maximum cutting speed	750 / 960 / 1,200 mm/s
Registration system	High speed - Vision3 CCD camera using 9th Generation ARMS technology
Job recognition	Advanced QR code for instant job recognition and registration

**GENERAL**

Media hold-down method	400W Vacuum suction
Acoustic cover for vacuum pump	Yes
Silencer	Optional
Stand	Included
Weight (uncrated)	69kg (152lbs)
Maximum dimensions* L x W x H	1068 x 860 x 1015mm



**FB780-T**

**Market position** Targeted for media up to 600-800 micron, the FB780-T has a larger cutting table, which can handle B2 folders and larger sheets. The head is upgraded, adding a higher pressure (2,500gf), Active Tangential tool which is supplied as standard with a Creasing Wheel to deliver a superior smooth crease.

The improved crease along with the ability to place 2 x SRA3 sheets next to each other or 4 x SRA4, for light production applications, enables users to achieve higher productivity due to less time taken placing sheets on the table, making this cutter is a very popular model.

Also includes a higher power 750W vacuum bed, to cut a wider range of media and an acoustic muffler, to ensure the flatbed comfortably fits within any work environment.

**MODEL FEATURES FB780-T**

Maximum media area	580mm x 800mm
Effective contour cutting area	480mm x 660mm
Selectable Tools / Force	Tool 1: Active Tangential Tool / 2,500gf Tool 2: Passive Contour Tool / 1,000gf
Cutting system	Blade Holder with Contour / Drag Knife Cutting Blade (Passive)
Creasing system	Tangential with Creasing Wheel (Active)
Speed settings	High Definition / Standard / Fast
Maximum cutting speed	750 / 960 / 1,200 mm/s
Registration system	High speed - Vision3 CCD camera using 9th Generation ARMS technology
Job recognition	Advanced QR code for instant job recognition and registration

**GENERAL**

Media hold-down method	750W Vacuum suction
Acoustic cover for vacuum pump	Yes
Silencer	Included
Stand	Included
Weight (uncrated)	84.4kg
Maximum dimensions* L x W x H	1190 x 1065 x 1105mm

Note to all devices:  
\* Maximum dimensions relate to assembled machines and reflect full extremities of each device to allow for aspects such as tool beam and vacuum hose.



**FB1180-T**

**Market position** With the largest cutting table in the range, the FB1180-T handles sheets up to B1+ (720 x 1020mm), with a maximum effective cutting area of up to 680 x 1020mm - ideal for larger sheets.

As the flagship model in the range, the FB1180-T, includes an enhanced cutting head with the flexibility of cutting corrugated / fluted boards N/F/ and E types (up to 3mm), yet with the precision and control to cut all media below including delicate label media.

The most flexible and productive machine in the range, the FB1180-T's head has 4 tool options, providing the user with a choice of either an Active Tangential OR Passive Contour tool for either tool position, delivering unparalleled flexibility. Users can maximise efficiency with a batch mode function, to cut multiple and mixed sheets up, on the table.

It is also delivered with a powerful 1100W vacuum fan.

**MODEL FEATURES FB1180-T**

Maximum media area	800mm x 1100mm
Effective contour cutting area	680mm x 1022mm
Selectable tools / force	Tool 1: Active Tangential OR Passive Contour Tool / 2,500gf 2 tools active at 1 time from selection of 4 Tool 2: Active Tangential OR Passive Contour Tool / 2,500gf
Cutting system	Active Tangential Knife or Passive Blade Holder
Creasing system	Active Tangential with Creasing Wheel or Passive Creasing Ball
Speed settings	High Definition / Standard / Fast
Maximum cutting speed	750 / 960 / 1,200 mm/s
Registration system	High speed - Vision3 CCD camera 9th Generation ARMS technology
Job recognition	Advanced QR code for instant job recognition and registration

**GENERAL**

Media hold-down method	1100W Vacuum suction
Acoustic cover for vacuum pump	Yes
Silencer	Included
Stand	Included
Weight (uncrated)	109kg
Maximum dimensions* L x W x H	1635 x 1350 x 1098mm

See full range specification table on back page



The optional ColorCut Pro Server Station streamlines production workflow and automates productivity.



# ColorCut Pro Server Station

The optional **ColorCut Pro Server Station** streamlines **production workflow** and **automates productivity**.

Realise the full potential of ColorCut Pro software, through the ColorCut Pro Server Station. Its innovative features will streamline the entire cutting process, increase workforce productivity, reduce costs and increase profits.

The Server Station provides an enhanced user interface, which significantly increases the power and functionality of ColorCut digital die cutters. Its additional software suite, frees up graphic designers' computers, so they can get on with the job of designing more jobs, while print finishing operators use the Server Station, as a production device to cut and crease jobs.

## Key features

- Mac or PC systems running ColorCut Pro can transfer cut files over the network to the Server Station Job Library
- Assigned job numbers and QR codes enable instant retrieval of the printed jobs associated cutting file
- Cut file settings can be adjusted without having to re-open the original design file
- No skilled operators required. ColorCut Pro stands alone

## What is the Server Station?

The Server Station is a hardware workstation & software bundle comprising of an ergonomic, free-standing pod, pre-installed with additional ColorCut Pro software suite, which includes:

- Production Studio + additional user licence
- Template Maker
- Job Library Manager

Running a stand-alone version of ColorCut Pro on the Server Station acts as a network hub enabling Mac and PC users to send their cut jobs from the ColorCut Pro client on their graphic design PCs &/ or MAC's, directly to the Server Station. This **builds a central library** of cutting jobs ensuring operator's can access all jobs saved to the ColorCut Pro Job Library at any time, without requiring Adobe® Illustrator® or CorelDRAW® and without having to re-open the original file. This frees up your graphic designers and enables them to continue working, making the server station a compelling addition for both Mac or PC environments.



## The software components explained

**Production Studio:** The core application for production and operating the cutter. The easy-to-use interface enables an operator to position sheets for cutting and click START on the software. The QR Code printed on the job sheet enables ColorCut Pro Production Studio to automatically and instantly retrieve the correct cutting file, then start cutting jobs. Job numbers can also be used, enabling an operator to load and send jobs directly to the cutter without need for any additional software.

**Job Library Manager:** Adds a sophisticated level of control enabling custom job naming and identification, viewing and even assigning unique or custom actions to specific QR codes or Job numbers.

**Template Maker:** Create die-cut templates for a range of simple cartons and shaped items with your own dimensions in just a few seconds. This intuitive program allows for a wide range of options to tailor X, Y, Z dimensions, flaps, tucks, creasing and perforations etc. Templates can then be exported to Adobe Illustrator or CorelDRAW for immediate use.

**Additional software licence:** A real benefit for the workforce, as it allows for two additional user seats for multiple ColorCut Pro Clients - which really helps in a networked environment.

*\*Only available with the ColorCut Pro Server Station.*

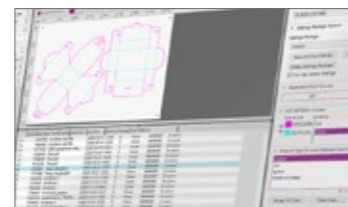

Job Library Manager - a repository for all saved cut files



Template Maker - create simple cartons and packaging designs

# ColorCut Pro Software

**ColorCut software** enables designers to generate cut files with **registration marks** and **QR codes** with associated **job numbers** as part of the design process.

## Software

### ColorCut Pro explained

ColorCut Pro consists of two parts, the first is the ColorCut Pro Client, a plug-in to Illustrator for Mac or PC creatives or to CorelDRAW (PC only). This enables designers/artworkers to generate cut files without the need to learn any new applications. The ColorCut plug-in also adds the ability directly into your graphics application to add both cut registration marks and QR codes with associated job numbers, easily, simply and as an integral part of the design process. It also saves each cut job into a ColorCut Pro job library for instant retrieval at any time, now or in the future.

Adding the QR codes and job numbers, is a key part of the ColorCut Pro magic, with QR codes the ColorCut flatbeds are able to retrieve previously prepared cut files without the need to launch Adobe® Illustrator® or CorelDRAW®. In fact this means, that after a graphic designer has sent the job to print, in a production print environment, any user can collect the sheets from the printer and cut them without needing to trouble the graphic designer to ask what cut file to use, or where it is stored.

## Cut by colour

### Colour recognition

ColorCut Pro makes cutting jobs simple. It is easy to set-up cutting, perforating, scoring, kiss-cutting and creasing processes by using different colours in the design.

ColorCut recognises different colours in the cut file allowing users to assign different operations, or the order in which they are performed. Another key advantage is colour assignment can be changed (if your customers use

different colours).



## Auto scan QR code and registration marks

### Cut file acquisition and job placement

The cutters in-built camera reads the QR code on each printed sheet and automatically retrieves the associated cutting file from the ColorCut Pro Job Library.

Additionally the camera reads the registration SmartMarks placed in each corner of the sheet, for positional accuracy. Advanced features compensate for print skew or positioning skew to ensure precise cut registration.

## QR driven workflow

### Process single/multiple or mixed jobs in the same run

The QR workflow has massive benefits in that it will access the correct cut file for each job placed on the cutting table, this means you can have each job uniquely different from the next, enabling the processing of mixed jobs in one pass.

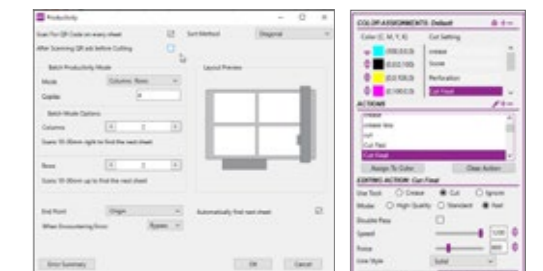

Batch productivity

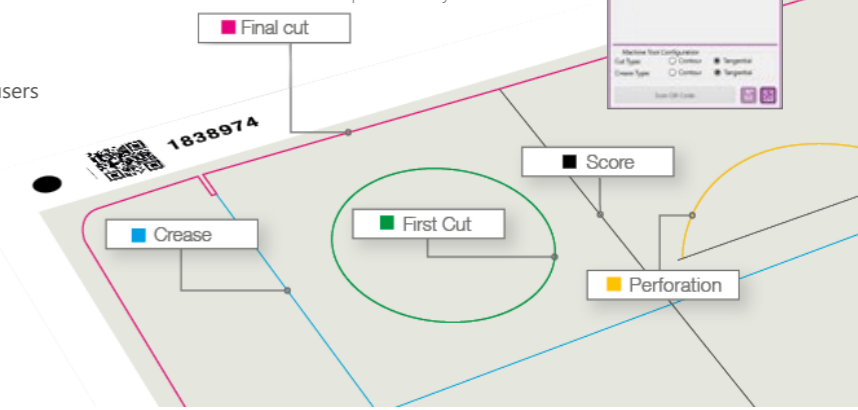

# Tools and Accessories

## A comprehensive range of tools and accessories, made for ColorCut.

A full range of original manufacturer parts and accessories are available for after-market purchase. Spares can be purchased at time of ordering the flatbed and/or shipped overnight as and when required.

### FB580

**Creasing ball tools.** Offering a choice of tips for either wide or narrow creases, as desired. Precision engineered, this tool sits in the tool 2 position.



**Options**  
**FBT0007** - Passive Drag Creasing tool - Wide  
**FBT0008** - Passive Drag Creasing tool - Narrow

**Cutting tool.** This precision engineered component sits in the dual tool head and holds the cutting blade of choice. The tool is manually adjustable to obtain the desired amount of 'blade out' for the job in hand.



**Options**  
**FBBLHOL** - Passive Contour / Drag Blade Holder tool

**Cutting blades.** These ultra-sharp and hard-wearing swivel/drag blades come in two types and three blade angles. Either as a pack of three the same or as a mixed pack.

#### Blades:

- Yellow** 30° 1mm ø - for film, very soft material, thin label material
- Red** 45° 1mm ø - typically for labels, stickers, and thin paper/card
- Blue** 60° 1mm ø - for hard media. The sharply angled tip provides a sharper point edge. Suitable for penetrating harder media types

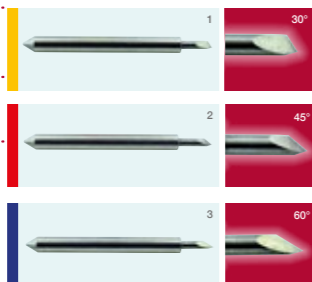

#### Circlip blades:

- Red** 45° 1.5mm ø - Most packing board up to 750 micron. Circlip provides better pressure and improves blade direction changes on dense media, from 0.25 to 0.75 mm thick
- Blue** 60° 1.5mm ø - For dense, rigid or thick media. Sharply angled tip provides a sharp point ideal for polyester, PVC or magnetic materials. 0.25 to 1.2mm



**Blade legend:**  
 1. 30° blade  
 2. 45° blade  
 3. 60° blade  
 4. 45° circlip knife  
 5. 60° circlip knife

### FB780<sup>T</sup>

**Creasing wheel tool.** Active Tangential Creasing Wheel tool with magnetic assist for easy change over. 3 different wheel options available for different media types. *Narrow tool provided with cutter.*



**Options**  
**FBT0008A** - Tangential Creasing tool - Narrow 0.28mm  
**FBT0008B** - Tangential Creasing tool - Medium 0.55mm  
**FBT0008C** - Tangential Creasing tool - Wide 0.95mm

**Cutting tool.** Passive Blade Holder tool for contour - holds the cutting blade of choice. The tool is manually adjustable to obtain the desired amount of 'blade out' for the job in hand. *Provided with cutter.*



**Options**  
**SC0003** - Passive Contour / Drag Blade Holder tool

### FB1180<sup>T</sup>

**Creasing wheel tool.** Active Tangential Creasing Wheel tool. 2 options available for different material types. *Both provided with cutter.*



**Options**  
**FBT0004W1** - Tangential wheel holder including tangential wheel 1 for E/F fluted boards  
**FBT0004W2** - Tangential wheel holder including tangential wheel 2 for N fluted, FBB/SBS/SBB packaging boards

**Cutting tool.** Active Tangential Cutting tool to hold a 45° blade. Blades shown are purchased separately. *Provided with cutter.*



**Options**  
**FBT0003** - Tangential blade holder

**Creasing tool.** Passive ball creasing tools; one narrow and one wide for different media or crease widths. *Both provided with cutter.*



**Options**  
**FBT0007** - Passive Drag Creasing tool - Wide  
**FBT0008** - Passive Drag Creasing tool - Narrow

**Cutting tool.** Passive Blade Holder tool to hold the cutting blade of choice. The tool is manually adjustable to obtain the desired amount of 'blade out' for the job in hand. *See Blade section on page 14.*



**Options**  
**FBBLHOL** - Passive Contour / Drag Blade Holder tool

**Tangential blade.** 45° 5.5mm blade for heavier / thicker stocks up to 3mm. Pack of 3 *provided with cutter.*

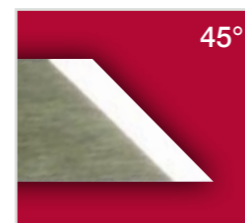

**Stock codes**  
**FBBLT45** - Tangential blades Pack of 3  
**FBBLT45-K15** - Tangential blades Pack of 15

# Tools and Accessories

## Universal tools and accessories

**Calibration tool.** A pen calibration tool is used at set up and then periodically, to calibrate the cutter.



**Cutting mats.** Green self-healing mat is manufactured from a particular rubberised compound enabling blades to sink into its surface without causing surface damage. This mat is ideal for obtaining crisp cuts on thinner materials. Vacuum suction flows through the perforations to hold printed sheets in position.

The grey felt mat is perfect for achieving deeper creasing lines and cuts on thicker substrates. The natural density of the fibres allows the vacuum flow to pass through it for sheet retention.



**Acoustic silencer.** Reduces sound level of vacuum pump. Provided with the FB780<sup>T</sup> and FB1180<sup>T</sup>, optional for the FB580.

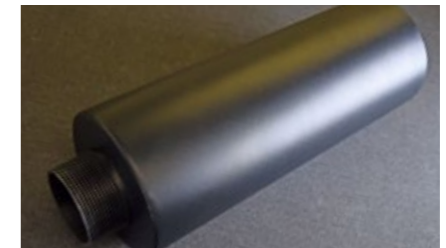



# Technical Specification

## ColorCut FB580

Max media size	440 x 580mm
Effective contour cutting area	340 x 480mm
Speed options	High Definition: 750mm/s Standard Mode: 960mm/s Fast Mode: up to 1,200mm/s
Format size	B3 (1 x SRA3 / 2 x SRA4) US (1 x Tabloid Extra)
Type of cut	Die-Cut, Half Cut (Kiss-cut) & Perf
Max. cutting depth	Paper/card up to 600micron. Maximum depth: 800micron (low density substrate i.e., softboard)
Dimensions	L 1068 x W 860 x H 1015mm (includes vacuum fan)
Power supply	100-240v 50/60Hz, 150W
Weight (unpacked) inc. stand	69kgs includes vacuum fan

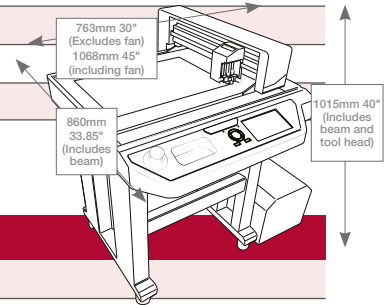

## ColorCut FB780<sup>T</sup>

Max media size	580 x 800mm
Effective contour cutting area	480 x 660mm
Speed options	High Definition: 750mm/s Standard Mode: 960mm/s Fast Mode: up to 1,200mm/s
Format size	B2 (2 x SRA3 / 4 x SRA4) US ARCH E2 (2 x Tabloid Extra)
Type of cut	Die-Cut, Half Cut (Kiss-cut) & Perf
Max. cutting depth	Paper/card up to 800micron. Maximum depth: 1,000micron (low density substrate i.e., rice paper / soft board) High Density Substrates: PVC - up to 0.4mm, PET - up to 0.3mm, magnetic sticker - up to 600µ
Dimensions	L 1065 x W 1190 x H 1105mm (includes vacuum fan)
Power supply	100-240v 50/60Hz, 350W (voltage specific)
Weight (unpacked) inc. stand	84.4kgs includes vacuum fan

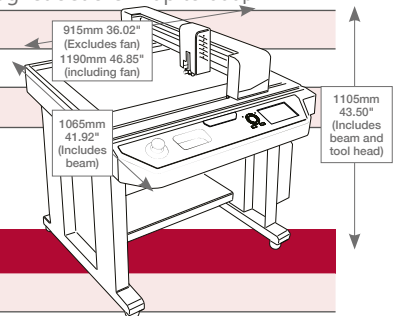

## ColorCut FB1180<sup>T</sup>

Max media size	800 x 1100mm
Effective contour cutting area	680 x 1020mm
Speed options	High Definition: 750mm/s Standard Mode: 960mm/s Fast Mode: up to 1,200mm/s
Format size	B1 (4 x SRA3 / 8 x SRA4) US ARCH E1 (4 x Tabloid Extra)
Type of cut	Die-Cut, Half Cut (Kiss-cut) & Perf
Max. cutting depth	Passive Tool: Paper/card up to 800micron. Maximum depth: 1000micron (low density substrate i.e., rice paper / soft board). Active Tangential Blade: Fluted / corrugated board up to 3mm
Dimensions	L 1635 x W 1360 x H 1098mm (includes vacuum fan)
Power supply	100-240v 50/60Hz, 350W (voltage specific)
Weight (unpacked) inc. stand	109kgs includes vacuum fan

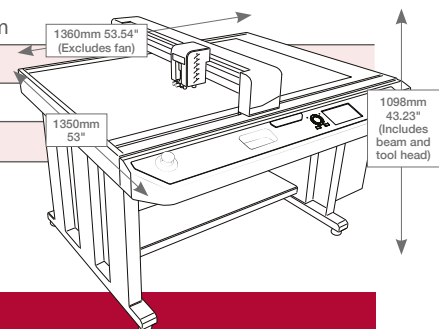

## Software and PC Specification - all models

ColorCut Pro 5 Plugin - PC	Adobe® Illustrator® CS6, CC2024 - CC2024 or CorelDRAW® X8, 2017 - 2024 Graphics Suite
ColorCut Pro 5 Plugin - Mac Client	Adobe Illustrator® CC 2022 - 2024. Mac operating systems: Big Sur to Sonoma
ColorCut Pro 5 Standalone - PC Only	Job server version - enables jobs created by the ColorCut Pro Plugin above to be cut at any time
Minimum PC specification	Windows® 10/11 Pro x64 bit. 4GB of RAM (8GB recommended). Monitor res: 1280 x 960 or higher

[www.intecprinters.com](http://www.intecprinters.com) • email: [sales@intecprinters.com](mailto:sales@intecprinters.com)

**\*Disclaimer** As part of our continued product improvement plan, specifications and information published here are subject to change without notice. All specifications are dependent on application, type of stock, temperature, RH and print engine used. Specifications quoted were measured on uncoated and unprinted stock. E & OE.